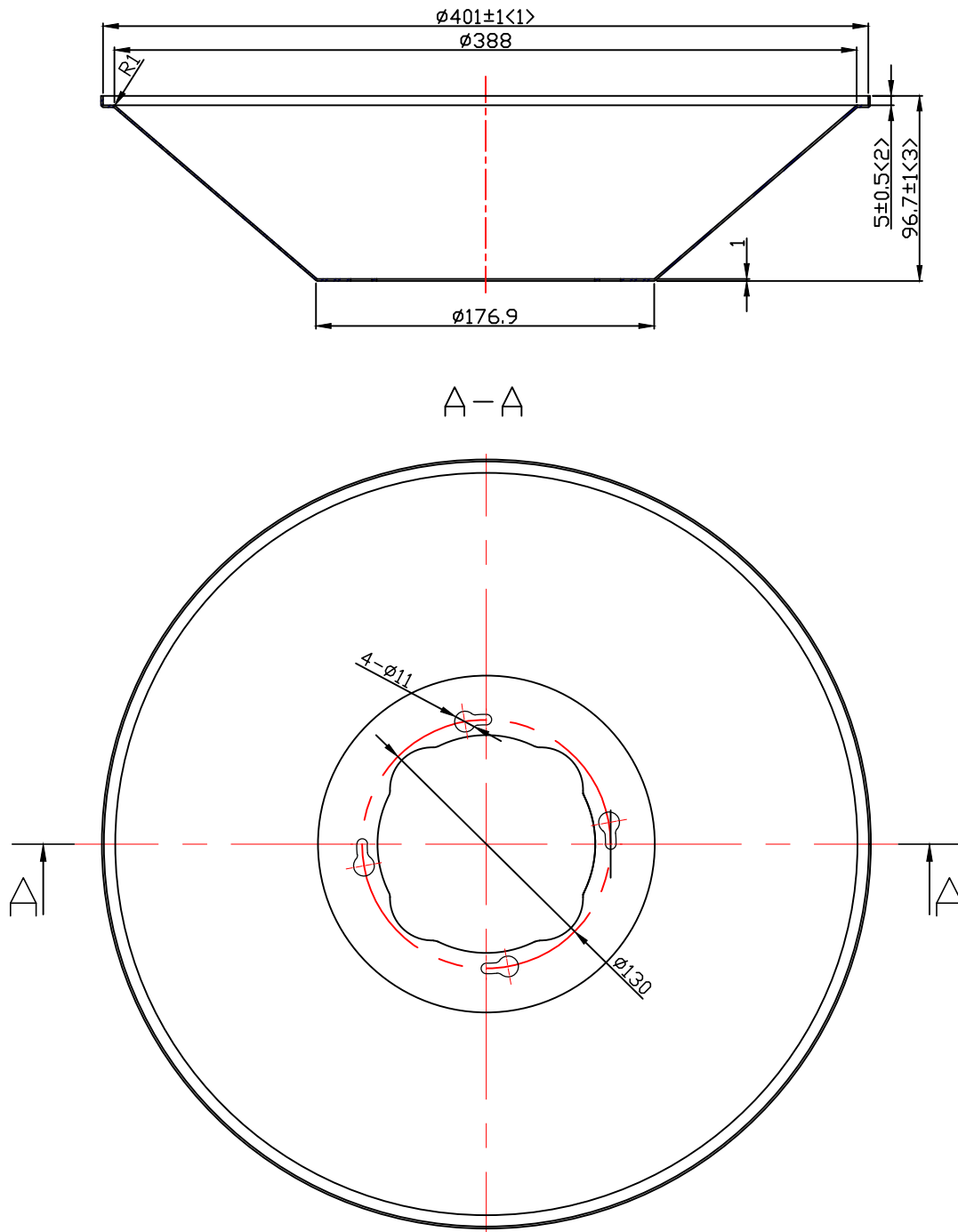

table for unmentioned tolerance in the drawing (unit: mm)			punch angle tolerance in the drawing (unit:degree)		
0-5	5-30	30-120	0-10	10-50	50-120
±0.15	±0.2	±0.5	±1°	±0.5°	±0.3°
120-250	250-400	400-700	120-250	250-360	360 above
±0.8	±1.5	±2	±0.2°	±0.166°	±0.083°



Technical requirements:

1. Material: t=1.0mm 1070AL.
2. Surface treatment: standard light.
3. Product tolerance reference tolerance table.

						Engineering drawings				<b>Nata<sup>®</sup></b> <b>NATA Lighting Co.,Ltd</b>	
										Customer Item	
										Customer Code	NT
										Product Number	91.15.0011.000
										Product Name	15-0011-A
Mark	Amended Times	Amended Content			Signature	Amended Date					
Control Version	AO	Design Version	KO		Client Version	1:1					
Designer		Drawing by			Proportion	1:1					
Technology		Auditor			View						
Approval		Date	2019.03.28		Page	Total_ Page_					